

cc = variations

product code

404-6XNN-LLL-CC0-Y

X = cable type / manufacturer  
 NN = wire count  
 LLL = length in mm  
 CC = variation  
 Y = performance level

X = cable type / manufacturer					
code	cable type / manufacturer	AWG	wire 1	temp range (static)	temp range (dynamic)
1	PVC / Klasing	30 7/38	red	-30°C to +105°C	-10°C to +105°C
2	TPE-S / Klasing	30 7/38	green	-55°C to +125°C	-40°C to +125°C
4	PVC / 3M	30 7/38	red	-20°C to +105°C	-20°C to +105°C
5	FEP / 3M	30 7/38	blue	-55°C to +125°C	-55°C to +125°C
6	LSZH / 3M	30 1/30	blue	-40°C to +90°C	-40°C to +90°C

NN = wire count	
12	
16	
20	
26	
32	
40	
50	
68	
80	

Y = performance level	
1	performance level 1

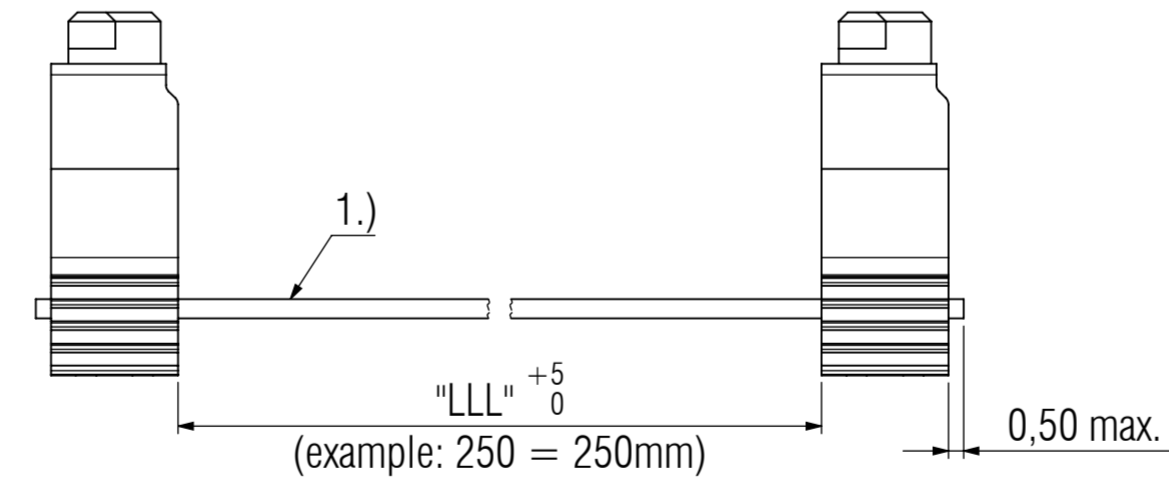
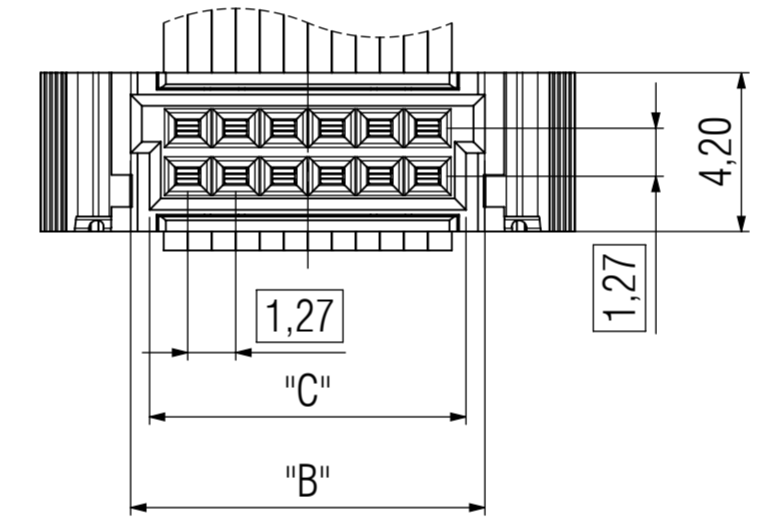
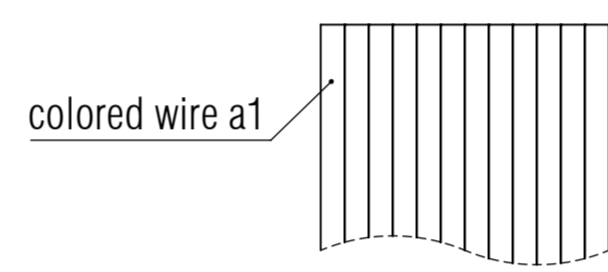
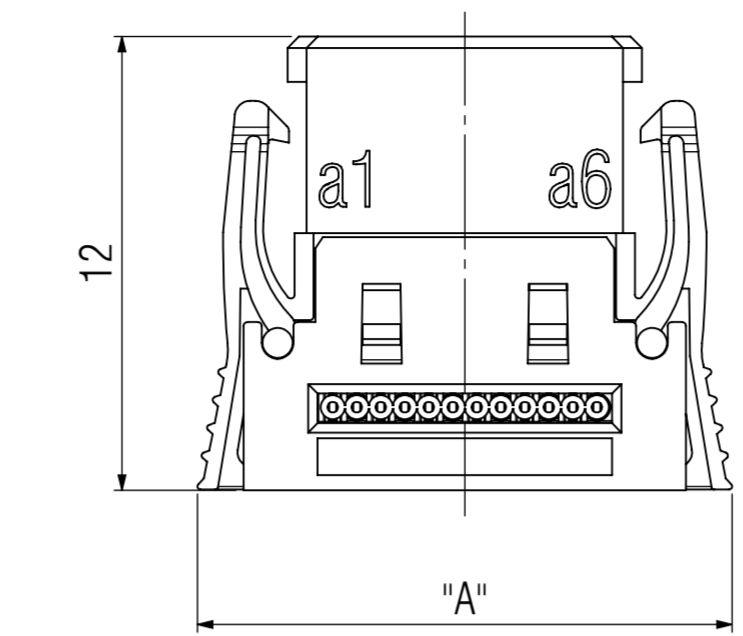

pin	"A"	"B"	"C"
12	14,14	9,37	8,37
16	16,68	11,91	10,91
20	19,22	14,45	13,45
26	23,03	18,26	17,26
32	26,84	22,07	21,07
40	31,92	27,15	26,15
50	38,27	33,50	32,50
68	49,70	44,93	43,93
80	57,32	52,55	51,55

1.) Printing: - partnumber  
 - date code

Technische Änderungen vorbehalten / all data subject to amendment without notice

Dokument Version / Document Version	Beschreibung der Änderung / Description of Change:	Werkstoff / Material:	A2
09	-		
Allgemeintoleranz / General tolerances		Maßstab / Scale: 2.5:1	
Tolerierungsgrundsatz / Fundamental tolerancing principle DIN EN ISO 8015		Verwendungsbereich / Range of application customer drawing	
Name / Name		Benennung / Description One27 cable connector	
09 revision	16.01.2024 R. Otte	Erststeller / initial creator	K. Reich
08 revision	06.05.2022 A. Oster	Gepr./Insp.	A. Asche
07 revision	13.01.2022 A. Oster		
06 revision	22.07.2020 G. Straß		
05 PCN 1892	21.08.2019 V. Milzi		
04 revision	03.06.2019 C. Höfle		
Version / Version	Änderung / Revision	Datum / Date	Name / Name
ept ept GmbH www.ept.de		Zeichnungsnummer / Drawing number 404-6XNN-LLL-CC0-Y	
Art / Type C		Blatt / Sheet 1 / 1 Status / Status	

© ept GmbH 2024. Weitergabe sowie Vervielfältigung dieses Dokuments, Verwertung und Mitteilung seines Inhalts sind verboten, soweit nicht ausdrücklich gestattet. Zuwiderhandlungen verpflichten zu Schadensersatz. Alle Rechte für den Fall der Patent-, Gebrauchsmuster- oder Geschmacksmustererträge vorbehalten.